

Arrow

Work booth

Design: Team Glimakra



GLIMAKRA
OF SWEDEN



Arrow

Work booth

Design: Team Glimakra

Arrow Work booth is an advanced and highly efficient product, developed to offer outstanding sound-absorbing properties. The construction is sturdy and opens up possibilities for innovative configurations. The wooden frame is finger-jointed with a pointed edge profile and round corners that are covered with fabric and piping.

DIMENSIONS

Work booth

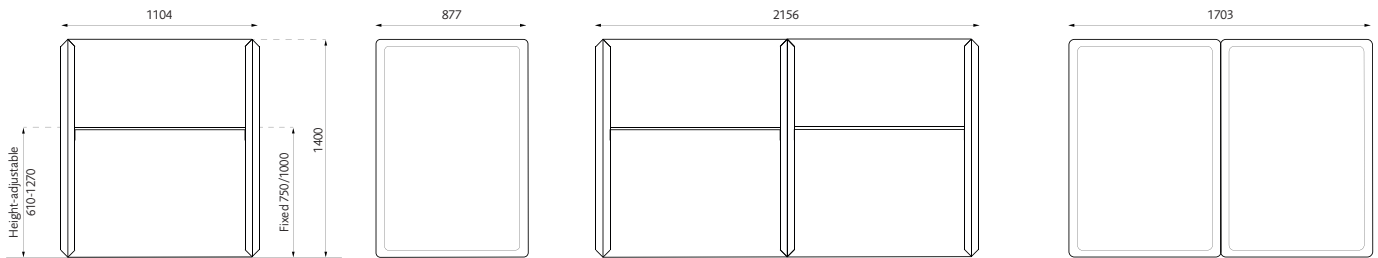

C-formation

Extension C

Extension S

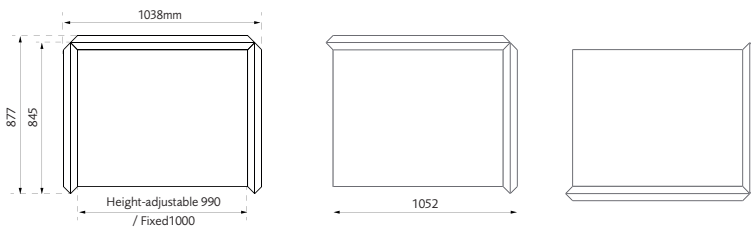

H-formation

Extension H

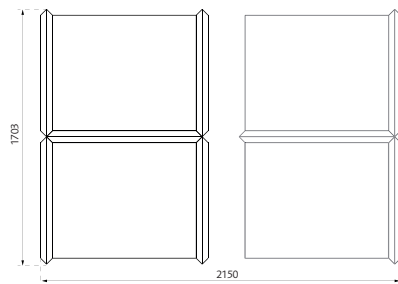

Quarter formations

Q-formation

Extension Q

Q Carousel

Q-formation

Extension S

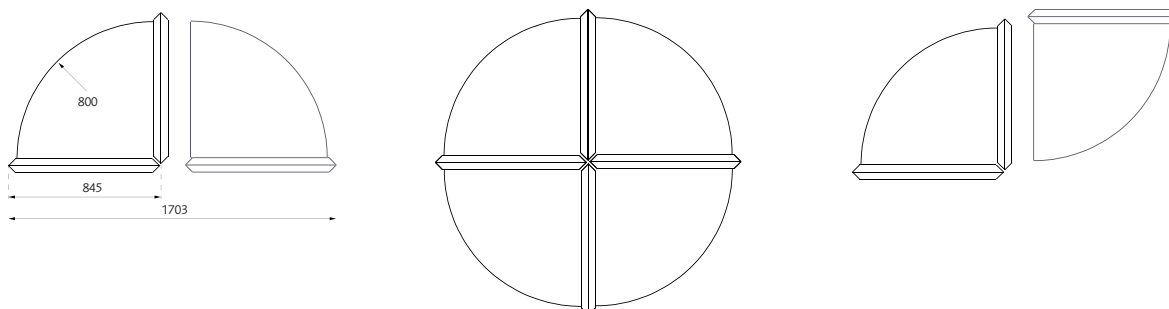

Arrow

Work booth

Design: Team Glimakra



DESCRIPTION

Frame: Finger-jointed wooden frame measuring 50x65 mm with a pointed edge profile and rounded corners, covered in fabric and piping. The workstations are connected with concealed fittings. The booth can have a fixed tabletop or a tabletop with an electric stand. Configurable in C-, S-, and H-formations, as well as quarter-circle configurations (Q). The booths stand on black conical leveling feet.

Upholstery: Furniture nailed with fabric on both sides. Circular and extra durable fabrics can be chosen to enhance the product's circularity. The nailing is concealed by a fabric piping.

Tabletop 22 mm: Ash, laminate, or linoleum with cable feed through and Powerdot.

Assembly: Connected with concealed keyhole brackets. Delivered unassembled.

100% recyclable materials.

FABRIC AND PIPING

Look in Product sheet Fabric and piping.pdf for our standard fabrics, you can download it here:

<http://glimakra.com/en/download/>

OPTIONS FOR FIXED TABLE-TOP

Fixed table-top: 1000x800 mm and Q800x800 mm.

Work surface in ash, laminate, or linoleum.

Two Ø60 mm holes for cable feed through and Powerdot.

Height: 750mm or 1000mm.

Ø60mm cable feed through in black between workstations and in table tops. The number of cable feed through can be increased if needed.

Powerdot Compact 62 with 1 type F power outlet, 1 USB-C charger 30W (black).

OPTIONS FOR HEIGHT ADJUSTABLE TABLE-TOP

Electric stand: DL11 Standard black, 1 pair including control box. External-mounted black electric stand with round legs.

Discreet holders that harmonize with the round shapes.

Table height: 610-1260 mm

Table top: 990x800 mm

Fillings

Setex PC 135 for maximum sound absorption
PureSound E for minimum weight.

Cable feed through in the screen: Ø60 mm hole in front screens and between workstations under the electric stand or the fixed table tops.

Integrated tool bar

Glimma or Uniform on the front screen. Refer to the price list under Accessories for current accessories.

CERTIFICATES

Acoustics: Measurements according to ISO 354. Evaluation according to the standard for individual objects SS 25269. (19-738-R1, date 2020-01-27. Akustikverkstan, a laboratory accredited by Swedac). The screens have an N_{10} value of 7.7 at 1 m². The total absorption of the screens gives a C-formation $N_{10} = 2.3$.

Glimakra of Sweden AB is certified according to ISO 9001:2015 and ISO 14001:2015.



CLIMATE IMPACT

The choice of finger-jointed wood in the frame maximizes the utilization of wood material from the forest compared to solid wood alone. The filling PC Setex consists of 100% post-consumer recycled material. Hemp piping consists of 100% plant based material. Choosing circular or recycled fabrics minimizes the climate impact.

SPECIFICATION TEXT

Arrow Work Booth C 1104x877x1400mm. Filling PC Setex 50. Fabric Blazer CUZ 18, Hemp piping. Black electric stand, Table top 990x800 mm ash 30. Concealed fittings integrated into the pointed profile.

Black cable feed through and Powerdot Compact 62 with 1 type F power outlet, 1 USB-C charger 30W (black).

Arrow

Work booth

Design: Team Glimakra



GLIMAKRA
OF SWEDEN



Arrow

Work booth

Design: Team Glimakra



GLIMAKRA
OF SWEDEN

